

MASSACHUSETTS INSTITUTE OF TECHNOLOGY  
ARTIFICIAL INTELLIGENCE LABORATORY

A.I. Memo No. 1026a

revised December, 1988

Demystifying Quantum Mechanics  
—A Simple Universe with Quantum Uncertainty—

Gary L. Drescher

## Abstract

An artificial universe is defined that has entirely deterministic laws with exclusively local interactions, and that exhibits the fundamental quantum uncertainty phenomenon: superposed states mutually interfere, but only to the extent that no observation distinguishes among them. Showing how such a universe could be elucidates interpretational issues of actual quantum mechanics. The artificial universe is a much-simplified version of Everett's real-world model (the so-called *multiple-worlds* formulation). In the artificial world, as in Everett's model, the tradeoff between interference and observation is *deducible* from the universe formalism. Artificial-world examples analogous to the quantum double-slit experiment and the EPR experiment are presented.

This report describes research done at the Artificial Intelligence Laboratory of the Massachusetts Institute of Technology. Support for the laboratory's artificial intelligence research is provided in part by the Siemens corporation.

Copyright © Gary L. Drescher 1988

# 1 Statement of the paradox

Isaac Newton's objective, mechanical world, grounded in an elegant collection of precise rules, seemed for a time to realize an ideal that had been sought for two millennia. Unfortunately, the preemption of classical physics by quantum mechanics is widely regarded—not least by physicists themselves—as a fundamental retreat from this ideal. Embarrassingly, physics—which ought to be the best exemplar of the mechanical paradigm—now seems to be its most formidable detractor.

The well-known nondeterminism of quantum mechanics is the least of its problems; probabilistic laws still afford a straightforwardly mechanical model. Far worse is the apparent observer-dependency of nature. Of the several states that a particle might be in, it seems that all coexist—as is shown, statistically, by their mutual interference—unless we try to observe this so-called *superposition* of states. Paradoxically, any such observation always reveals just one of the thitherto-coexisting states. (Which of the states we observe is unpredictable in principle—hence, the nondeterminism of quantum mechanics.)

## 1.1 The double-slit experiment

The classic double-slit experiment highlights the paradox. We aim an electron at a pair of adjacent, narrow slits in a barrier (imagine this happening in just two dimensions). Beyond the barrier lies a backdrop with a row of densely-packed electron detectors (each of the same resolution as the width of each of the slits; the distance between the two slits is much greater than this resolution). If the electron passes through the barrier via the slits, we find that one (and only one) detector soon registers the arrival of the electron.

Suppose we block one of the two slits and conduct many trials of this experiment, plotting the distribution of electron-arrivals at the various detectors. Not surprisingly, we see a smooth curve with a peak opposite the unblocked slit. If instead we unblock the other slit, then, of course, the distribution curve has a peak opposite that other slit. If we conduct a number of trials, half with one slit blocked and half with the other blocked, the distribution curve is just the sum of the two single-slit curves. All this is consistent with the electron's being a particle that is smaller than the width of each slit, and that passes through one unblocked slit or the other.

But now, suppose we try the experiment with both slits unblocked. Bizarrely, the distribution curve is not the expected sum of the single-slit curves. Rather, the curve shows an interference pattern; at some points along the backdrop, the frequency of an electron's arrival is not only less than what the sum of the single-slit curves predicts; it is less than what either single-slit curve *alone* would predict. The distribution seen over a large enough number of trials must approximate the sum of the probability distributions of the individual trials; hence, by providing an additional path by which an electron might arrive at a certain point along the backdrop, we have *reduced* the probability of its arriving there on a given trial.

This result is inexplicable if the electron indeed passes through just one slit

or the other; if a given electron encounters just slit A, opening slit B could not reduce the likelihood of the electron's reaching a given destination through slit A. But the interference is just what we would expect if the electron were not a spatially localized particle, but rather an expansive wave—a wave that passes through both slits, creating usual wave-like interference on the other side of the barrier. Indeed, the observed interference pattern accords quantitatively with the predictions of wave mechanics. The wave's amplitude at a given point corresponds to the probability that the electron arrives there, as seen by a detector at that point.

But this raises an apparent paradox. If the electron spreads out in a wave-like fashion, why does the backdrop detect only a local, discrete arrival for each electron? The universe seems to be playing hide-and-seek: when we look for the electron, we see a particle; but when we're not looking, the electron seems to act like a wave, passing simultaneously through two widely separated slits (widely separated compared to the size of the particle), and exhibiting interference on the other side.

We might seek to clarify the situation by shining a light source on the barrier to see the electron as it passes through. In that case, we unambiguously see the electron emerge from just one slit or the other. But then, the distribution curve, over many such trials, no longer shows interference; instead, it simply equals the sum of the single-slit curves.

## 1.2 The interference-observation duality

Thus we have the fundamental, paradoxical duality:

- There are coexisting, mutually interfering states, so long as the states are not distinguished by observation. (Here, there is a continuum of such states, propagating in a wavelike fashion.)
- Whenever an observation is made, only one of the superposed states is ever seen. (Here, a conventional particle, much smaller than the wave, is all we see if we look.)

This is known as the quantum-mechanical *wave-particle* duality. A standard understatement of this duality is that an electron (or other physical entity) acts sometimes like a wave, sometimes like a particle. More strikingly, we have here an *interference-observation* duality: there are many superposed, mutually interfering states whenever we're not "looking", but only one state whenever we do look. Heisenberg's uncertainty principle says, moreover, that no matter how precise an observation we perform, some superposition must remain; indeed, the more precisely we measure a given attribute, the more superposition there is with respect to some other attribute.

To see how dramatic the interference-observation duality really is, consider Wheeler's *delayed-choice* modification of the double-slit experiment: one does not decide, until after the electron passes the barrier, whether to collect the electron

against the backdrop, or whether to pull the backdrop out of the way and observe which slit the electron came through—by using a pair of “telescopes”, each focused on one slit. If we choose to remove the backdrop and make the observation, we see that the electron passed through just one of the slits. If we choose not to observe, what we see (over many such trials) is only consistent with the “particle” having passed, wave-like, through *both* slits on *each* trial, the two parts of the wave then mutually interfering. What, then, does the electron do when it reaches the barrier, prior to the decision whether to observe where it comes from: does it pass through one slit or both? It seems that the answer is determined *in retrospect* when the distinguishing observation is made, or when the electron instead reaches the backdrop unobserved.

### 1.3 Interpretations: Copenhagen and Everett

The standard interpretation of such phenomena—the *Copenhagen* interpretation—shows the profound effect of this paradox on physicists’ sense of reality. According to the Copenhagen interpretation, no physical phenomenon is real until it has been observed. Nothing real passes through both slits of the apparatus; there is a potential for a real particle to pass through either slit, but that potential is not realized unless the passing-through is observed. This interpretation does, indeed, accord with the fact that the particle cannot simply pass through just one of the slits (else the interference wouldn’t be seen statistically), and with the fact that that is just what the particle has done whenever we look to see. But it gains this accord at the price of denying the observer-independent existence of things in the world.

Thus, quantum mechanics seems to challenge not just the world’s determinism, but the very objectivity of its existence. Indeed, the Copenhagen interpretation provides no way to express the state of universe as a whole, since a system’s state is real only with respect to an external observer, and the universe as a whole has no external observer.

This is not yet the worst of it. The Copenhagen interpretation exhibits the usual rigor of physics to say what happens to the world *between observations*; this is given by Schrödinger’s equation, which governs the (fully deterministic) propagation of a (wave-like) quantum state of the universe. This state is a superposition of many individual, sometimes mutually interfering states (such as the state of an electron being at one slit or the other). When an observation occurs, Copenhagenists insist that the superposition of states *collapses*, leaving just one member of the previous superposition. Schrödinger’s equation itself does not predict any such event as this collapse.

What’s worse, the Copenhagenists have no formal criterion for what constitutes an observation (hence for when the putative collapse occurs). Is the detection of a quantum event by a laboratory instrument an observation? Von Neumann [von Neumann55] showed that the same prediction is made whether one stipulates a collapse at that point, or whether, on the contrary, one regards the superposition

as persisting<sup>1</sup> (so that now, the macroscopic instrument is itself in a superposition of more than one detection state). Here, then, is the worst of it: only when a conscious being observes the state of the instrument—and sees that it is unambiguously in one state or the other—does it become clear (so the argument goes) that only one outcome really occurred. Thus was von Neumann (of all people) led to conclude that human consciousness (of all things) plays a fundamental role in physics: conscious observation precipitates the collapse of the quantum superposition.

Most physicists, unlike von Neumann, accept that inanimate observation suffices to bring about the collapse. Still, a number of eminent theoretical physicists share von Neuman’s version of the Copenhagen interpretation. Disturbingly, quantum physics turns mechanists into mystics.

Fortunately, there is an alternative interpretation of quantum mechanics that restores intelligibility to the universe. Quantum phenomena such as the double-slit experiment show that, prior to observation, the superposed states have symmetric status; that is, no one of the superposed states is already the unique real one. (*Hidden-variable* theories try to deny this, but such theories are provably wrong; see section 5.5.) Logically, then, there are two ways to achieve this symmetry: either none of the superposed states is real, or all of them are. The Copenhagen interpretation says none are real; Everett’s so-called *multiple-worlds* interpretation [Everett57] says all of them are real.

In Everett’s formulation, the quantum collapse never occurs. Superposed states remain in superposition even after observation (whether by inanimate objects or by conscious observers). It remains to account for the *apparent* collapse—the fact that we see only one outcome of the quantum observation. In Everett’s account, the universe, in effect, splits into multiple branches upon each quantum observation; each branch contains a particular outcome, along with an observer that has seen that outcome to the exclusion of any others. Thus, versions of the observers themselves are in superposition; but they are mutually isolated, so each sees an apparently unique outcome. As we shall see, the formal version of this model—in contrast with its English paraphrase—is elegant and plausible.

In this paper, I try to make sense of the quantum-mechanical universe. Often, the best way to understand a thing is to build one. Hence, I build a universe, a qualitative model of quantum mechanics. That is, I define a universe whose physics are quite different from (and much simpler than) our own world’s; and I demonstrate that this universe exhibits an interference-observation duality analogous to that of real physics. (We can call this model *quantish physics*.) The analogy runs deep enough to support a comparison of the “Everett” and “Copenhagen” interpretations with respect to the qualitative model; this comparison elucidates the interpretation of real physics.

---

<sup>1</sup>Actually, the same prediction is made only when some trace of the observation persists; see section 6 for elaboration.

I present three artificial “universes”: U1, U2, and the quantish physics model. The first of these universes, U1, has straightforwardly “classical” mechanics. U2 attempts to incorporate quantum-like uncertainty in its physics, but fails in instructive ways. Finally, the *quantish physics* model, building from the U2 attempt, succeeds in qualitatively reconstructing the fundamental quantum interference-observation duality.

## 2 U1: “Classical” physics, configuration-space representation.

Let us define a universe consisting of a circuit built from Fredkin gates [Fredkin82]. A Fredkin gate has three binary (0 or 1) inputs and outputs; each output computes a boolean function of the inputs, as specified by figure 1a. But the gate is more easily understood in terms of figures 1b and c. The first input is a *control wire*; if it has a 0, then, after a unit time delay, the second and third inputs (*switch wires*) simply propagate to the second and third outputs, respectively.<sup>2</sup> If the control wire has a 1, then the other two wires “cross”, so the second input comes out at the third output, and vice versa. The control wire simply propagates its input to its output, again with unit time delay. Fredkin gates, unlike some logic gates, do not allow fan-in or fan-out; rather, each output must connect to exactly one input.

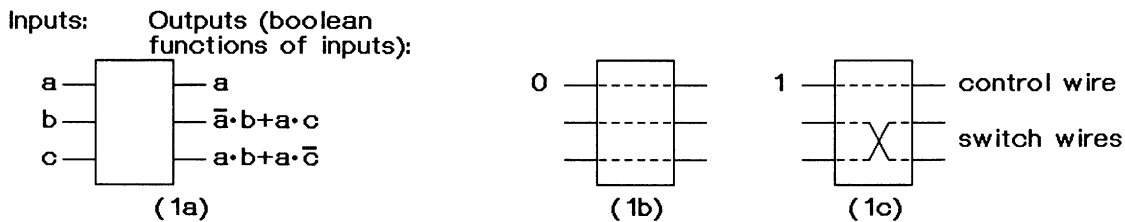

Figure 1: A Fredkin gate.

Fredkin gates (like NAND gates) are *universal*. (Loosely speaking, their universality means that any logic circuit that can be built at all can be built using only Fredkin gates.) Fredkin gates have the further property of *conserving ones and zeros*—that is, the number of ones (or zeros) that leave a gate equals the number that entered the gate one time-unit earlier; hence, the total number of ones (or zeros) coursing through the circuit remains constant.

For a given “universe” (that is, a given Fredkin-gate circuit), one might represent the state of the universe at a given time by listing, for each wire, whether that wire has a one or a zero; hence, the state can be represented by a vector  $(v_1, \dots, v_n)$ , where  $v_i$  is 0 or 1 according to the state of the  $i^{\text{th}}$  wire, and  $n$  is the

<sup>2</sup>In [Fredkin82], delays occur in the wires rather than in the gates.

number of wires in the universe. (A wire goes from an output to an input; a gate's output wires are distinct from its input wires.)

Alternatively, because Fredkin gates conserve ones and zeros, we can index the world-state the other way around: for each 1—think of 1's as “particles”—we can say at which wire it currently resides. We'll construe a particle as passing through a gate in the obvious fashion: a particle on a gate's control-wire input emerges from the gate's control-wire output; a particle at one of the two switch inputs either proceeds straight across, or crosses over, depending on the control-wire state. (To specify which wire a particle is at is to fully specify the particle's position; no gradations of position along a wire are recognized.)

Let us now present the particle-indexed state geometrically. If the universe has  $k$  particles, we define a  $k$ -dimensional space; each dimension has discrete coordinates ranging from 1 to  $n$  (the number of wires in the universe). For a given point  $(p_1, \dots, p_k)$  in this space, the point's  $i^{\text{th}}$  dimension says which wire the  $i^{\text{th}}$  particle is at; call this space *configuration space*. A single point in configuration space represents the entire state of the universe.<sup>3</sup> Rephrasing the physics of this universe in terms of configuration space, we get a rule for moving from one point in this space to another at each unit-time interval.

Figure 2 illustrates this formulation. Suppose gate  $g$  appears in the Fredkin circuit defining our model universe; suppose for now that there exist just two particles,  $p_1$  and  $p_2$ .  $p_1$  appears at  $g$ 's control wire,  $p_2$  at  $g$ 's upper switch wire. Figure 2 shows the configuration space point  $S$  that designates this state of the universe; at the next time unit, the state of the universe becomes  $S_1$ ; in that state,  $p_1$  has moved to  $w_{1a}$ , and  $p_2$  has crossed over to  $w_{3a}$ .

The configuration space representation is equivalent to, but more cumbersome than, the more obvious wire-vector representation. But in the following sections, we shall see how this representation supports the introduction of quantum-like phenomena to our Fredkin-gate universes.

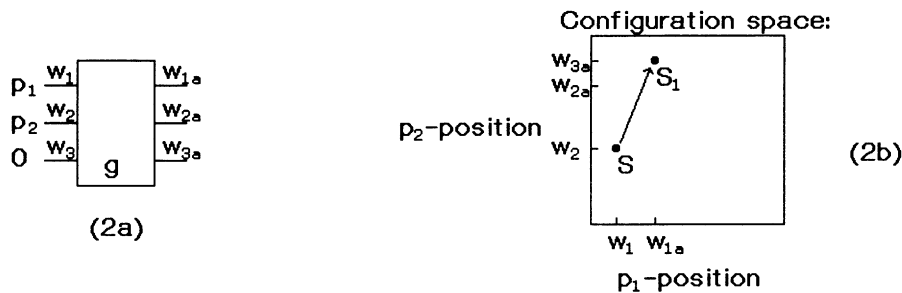

Figure 2: A state moves through configuration space.

<sup>3</sup>Configuration space is analogous to *phase space* in real-world classical physics. For a system with  $k$  objects, phase space has  $6k$  dimensions: three dimensions for each particle's position and momentum. Thus, a single point in phase space specifies the position and momentum of every object.

### 3 U2: A universe with non-interfering superpositions

Suppose we modify the classical physics to allow a superposition of states to coexist. Rather than representing the state of universe by a single point in configuration space, we assign a *weight* (in  $[0,1]$ ) to each configuration-space point; the weights sum to unity. In U1, a single point changed its configuration-space coordinates at each unit-time interval. In U2, all weighted points move simultaneously, carrying their respective weights along; each moves according to the same rules that governed the single point in U1.

To avoid ambiguity, we now say that each point in configuration space represents a *classical* state of the universe; the entire set of weight assignments in configuration space is a *quantum state*. In U2, the state of the universe is the quantum state, which we say is a superposition of its nonzero-weighted classical states. (When no ambiguity will result, I continue to speak of a “state”, with “classical” or “quantum” left implicit.)

We may think of the weights in configuration space as probabilities; the set of weight assignments specifies a probability distribution as to what classical state the universe is in. But note that the physical laws of U2 are not, in fact, probabilistic. They are deterministic laws that push weights through configuration space, though it will be helpful to think of these weights as probability measures.

Figure 3a shows a fragment of a Fredkin-gate circuit. (Here and throughout, unconnected wires are understood to connect to gates not shown.) Particle  $p_1$  is in a superposition of two positions,  $w_1$  and  $w_2$ ; particle  $p_2$  is at  $w_3$ , and  $p_3$  is at  $w_4$ . Figure 3b shows a three-dimensional cross-section of configuration space with dimensions corresponding to the positions of the three particles. Figure 3b shows this situation from configuration space. States  $S_{1a}$  and  $S_{1b}$ , each with weight .5, correspond to the superposed positions of  $p_1$ .

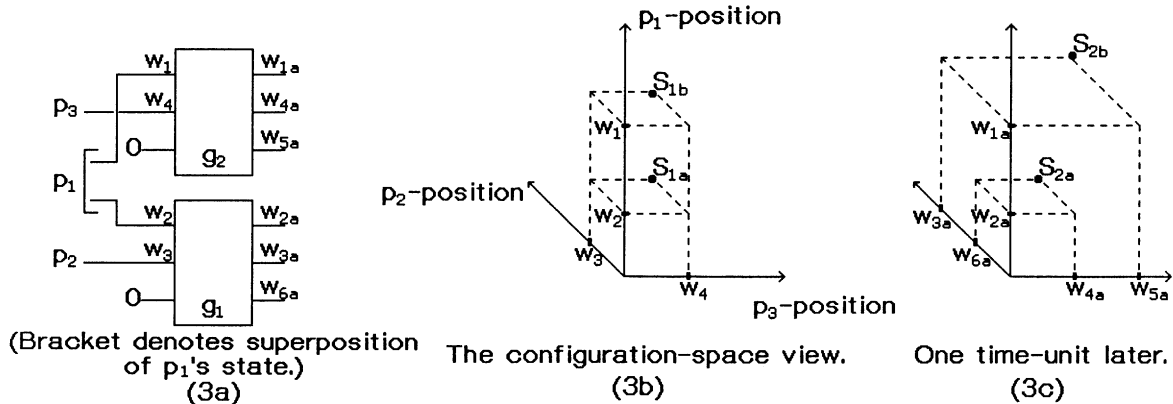

Figure 3:  $p_2$  and  $p_3$  observe  $p_1$ 's position.

Note that the three particles' positions are mutually independent: in particular,  $p_2$ 's position and  $p_3$ 's position are the same whether  $p_1$  is at  $w_1$  or  $w_2$ . One time unit later, though, the gates have correlated  $p_1$  with  $p_2$  and  $p_3$  (as shown in



figure 3c). There is still a superposition of two world states,  $S_{2a}$  and  $S_{2b}$ ; in each,  $p_2$  is at  $w_{3a}$ , and  $p_3$  at  $w_{5a}$ , if and only if  $p_1$  is at  $w_{1a}$ . Hence, the position of  $p_1$  has been “observed” by  $p_2$  and  $p_3$ . Although the universe still contains a superposition of two states for  $p_1$ ,  $p_1$ ’s state *relative to*  $p_2$ ’s (to use Everett’s terminology) is unambiguous:  $p_1$  is at  $w_{1a}$  relative to  $p_2$  at  $w_{3a}$ ;  $p_1$  is at  $w_{2a}$  relative to  $p_2$  at  $w_{6a}$ . Similarly,  $p_1$ ’s state is unambiguous with respect to  $p_3$ ’s state.

Note the consistency of the two observations of  $p_1$ . There are only two possible outcomes: one state where  $p_2$  crosses over and  $p_3$  doesn’t, so that only  $p_2$  was diverted by  $p_1$ ; and, symmetrically, a state where only  $p_3$  was diverted by  $p_1$ . Hence, either state is consistent with  $p_1$  being at  $w_1$  or  $w_2$ , but not both. Moreover, it is easily verified that any subsequent observations—of  $p_1$ ,  $p_2$ , or  $p_3$ —will maintain this consistency. By virtue of this consistent repeatability, the interactions with  $p_1$  are what Everett calls *good observations*.

Prior to the observation,  $p_1$  was in a superposition of two states. Subsequently, although this superposition continues, there are two branches of the universe, each consistently and unambiguously showing one state of  $p_1$ . Thus, we might try to construe this interaction to model the apparent collapse of the quantum superposition—apparent, that is, from the standpoint of any observer embodied in U2.

But that construal would be wrong. In fact, from within U2, there was never any apparent superposition to begin with; hence, the observation did not appear to collapse any superposition. The problem is that there is no “interference”—no interaction at all—among the superposed classical states. Each such state has a unique immediate predecessor as well as a unique immediate successor (because, as is readily seen, a Fredkin gate’s outputs uniquely specify what the inputs must have been, as well as vice versa). Thus, two superposed classical states never converge; each evolves entirely independently of the other, moving through configuration space without interfering with the other. Therefore, the superposition is evident only to an observer external to the entire universe who can examine configuration space directly. To any observer embodied in any “branch” of the universe (any element of the superposition), there is never any evidence of the existence of any other branch. Hence, as seen from within this universe, the universe appears entirely classical; it is indistinguishable from U1. In particular, the 1’s behave like ordinary “particles”, just as in U1.

## 4 The laws of quantish physics

In this section, I present laws of physics that are analogous to real quantum mechanics, under the Everett interpretation. Indeed, this section largely recapitulates Everett’s relative-state formulation of quantum mechanics, but with Fredkin-gate mechanics substituted for quantum wave mechanics. The interference-observation duality of real-world physics—that superposed states interfere with one another if, and only if, no observation has distinguished among them—is a property of quantish physics as well.

The quantish physics model extends and modifies the U2 model. Quantish physics has three characteristics that distinguish it from U2 physics: multiple successor and predecessor states; complex rather than real-valued weights; and a binary-valued *attribute bit* associated with each particle.

In U2, each classical state has a unique successor and predecessor, so distinct states do not interfere. In the quantish model, a classical state can have multiple immediate successors and predecessors. A configuration-space point's weight splits into components that each contribute to one of the point's immediate successors; the contributions of multiple predecessor points to a common successor simply add.

To facilitate interference, quantish classical states are assigned complex weights rather than real-valued weights. The probability measure associated with a classical state is the square magnitude of its weight; in every quantum state, the classical states' probability measures sum to unity. When a classical state splits into two successors, its weight splits into two orthogonal components of the original weight, so the sum of the successors' probability measures equals the predecessor's probability. When several configuration-space points contribute to a common successor point, the sum of the contributing weights has a square magnitude that may be less than or greater than (or equal to) the sum of the contributing square magnitudes; this provides for destructive and constructive interference.

Each quantish particle has an *attribute bit*, whose value is either + or -; and each gate has a *measurement vector*, a two-dimensional vector with real-valued coordinates. (The magnitude of a measurement vector will turn out to be irrelevant; only its angle matters.) Measurement vectors cannot change, and are simply built into the universe, as is the circuit topology. Attribute bits can change, and so each particle's attribute-bit value is part of each quantish classical state, and must be represented in quantish configuration space. Therefore, quantish configuration space has *two* dimensions for each particle: one, as in U2, for the particle's position, and the other for the particle's attribute bit. Each attribute-bit dimension has just two discrete coordinates, one corresponding to the + attribute, the other to the - attribute.

As with U2, quantish physics is defined by laws that say, for any classical state, where each particle next moves to (and what its next attribute-bit value is). As in the previous model, these laws translate into a rule that specifies the coordinates of a classical state's successor point in configuration space; the weight associated with the predecessor point moves to the new point.

But in the quantish model, a given particle in a given classical state can have two next positions, and two next attribute-bit values, rather than just one. This multiplicity of destinations and attribute values for a particle corresponds to a four-fold split in the given classical state. That is, the given state has four successor states rather than a single successor; there is one successor state for each permutation of one of the two destinations, and one of the two attribute values. Thus, no successor state shows the particle simultaneously at more than one position, or with more than one attribute value; rather, there is a distinct classical

state for each of the alternatives.

The given state's weight divides among the four successors, as described below. More generally, in a given classical state, there may be  $n$  particles with two next positions and attribute values each; then, there are  $4^n$  successor states, one for each permutation of the binary position and attribute-bit choices for each of the  $n$  particles.

Defining quantish physics, then, requires specifying:

- How particles move through gates—the rule for a particle's next position (or positions), and next attribute-bit value (or values); and, in the event of multiple destinations or attribute values, the rule by which a configuration-space point's weight divides among its successor points.
- The rule by which weights combine when multiple predecessors have one or more successor points in common.

How particles move through gates is explained just below. The rule for combining weights is trivial: as mentioned above, when several configuration-space points each contribute a portion of their weight to a common successor point, the contributed weights simply add. This, together with the fact that a classical state's successors are a function of that state alone (regardless of any other classical states superposed in the quantum state), ensures that the quantish state-succession (like real-world quantum-state evolution) is *linear*. That is,  $\text{successor}(q_1 + q_2) = \text{successor}(q_1) + \text{successor}(q_2)$ , where the successor function maps a quantum state onto its successor quantum state;  $q_1$  and  $q_2$  are quantum states, and  $q_1 + q_2$  is a quantum state whose weight at each configuration-space point is the sum of  $q_1$ 's and  $q_2$ 's weights at that point.

A particle at the control-wire input to a quantish gate simply passes through to the control-wire output, as in U1 and U2; its attribute bit remains the same. However, a particle that is at a gate's switch-wire in a given classical state behaves differently than in U1 and U2: roughly speaking, the particle emerges at *both* of the gate's switch-wire outputs, with *both* attribute-bit values at each destination, as illustrated in figure 4a.

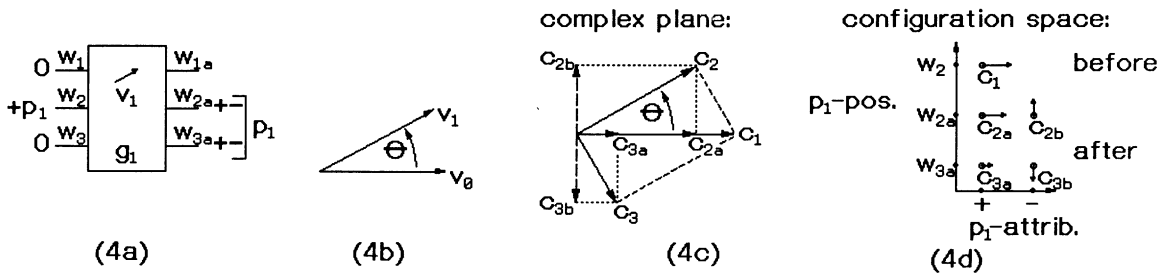

Figure 4: A classical state with weight  $c_1$  splits into four successors.

More precisely, the given classical state has multiple successors, half of which show the particle emerging at the upper switch wire, half at the lower switch wire.

The division of the given state's weight  $c_1$  is as follows. We take  $p_1$ 's attribute bit to designate a two-dimensional vector  $v_0$ : the vector  $(1, 0)$  if the bit is  $+$  (as it is in this example), or  $(0, 1)$  if the bit is  $-$ . We define  $\theta$  to be the angle from  $v_0$  to gate  $g_0$ 's measurement vector  $v_1$  (see figure 4b).  $c_1$  then divides into two orthogonal components,  $c_2$  and  $c_3$ ;  $c_2 = \cos \theta e^{i\theta} c_1$ , and  $c_3 = \sin \theta e^{i(\theta - \frac{\pi}{2})} c_1$ , as figure 4c illustrates. Note that this decomposition into orthogonal components conserves the probability measure that we have defined:  $|c_1|^2 = |c_2|^2 + |c_3|^2$ .

If there is no particle at  $g_1$ 's control wire (as in this example), then  $c_2$  is divided among those successor points that show  $p_1$  having passed straight across to the corresponding switch-wire output (in this example, the upper wire), and  $c_3$  is divided among successors that show  $p_1$  having crossed over. If there were a particle at the control wire, the assignment would be reversed,  $c_2$  corresponding to crossing over,  $c_3$  to passing straight across.

Weights  $c_2$  and  $c_3$  each subdivide further, between successors showing  $p_1$  with the same attribute bit, or the opposite bit, that it had when entering the gate. The weights divide as shown in figure 4c. Each splits into two orthogonal components, one parallel to  $c_1$  in the complex plane, the other perpendicular. (Again, note that the probability measure is conserved.) Each of  $c_{2a}$  and  $c_{3a}$ —the components of  $c_2$  and  $c_3$  that are parallel to  $c_1$ —moves to a successor state that has  $p_1$ 's attribute unchanged; the other two components,  $c_{2b}$ , and  $c_{3b}$ , move to successors in which  $p_1$ 's attribute has switched. Figure 4d depicts a cross-section of configuration space that shows the original weight  $c_1$  and the four components into which it splits; the arrow at each point designates the corresponding weight as a vector in the complex plane.

Each of  $c_1$ 's components  $c_{2a}$ ,  $c_{2b}$ ,  $c_{3a}$ , and  $c_{3b}$  is expressible as the product of  $c_1$  and another complex factor ( $c_{2a} = c_1 \cos^2 \theta$ ;  $c_{2b} = c_1 i \cos \theta \sin \theta$ ;  $c_{3a} = c_1 \sin^2 \theta$ ; and  $c_{3b} = -i c_1 \sin \theta \cos \theta$ ). When a classical state has  $n$  particles at switch wires, there are  $4^n$  successor states, as noted above. The weight for each successor state is the product of the original weight and  $n$  complex factors, one for each of the  $n$  splitting particles, each factor corresponding to the position and attribute bit of that particle in that successor state.<sup>4</sup> This  $4^n$ -fold splitting also conserves probability; it is equivalent to  $n$  successive four-fold splits, each conserving probability.

Suppose a particle at a switch-wire input of some gate has a  $+$  attribute-bit value, and the gate's measurement vector is  $(1, 0)$ . The above rules imply that in this important special case, the gate treats the particle as would a U1 or U2 gate—that is, if there is no particle at the gate's control-wire input, the switch-wire particle passes straight across; if a control-wire particle is present, the switch-wire particle crosses over. This behavior follows from the fact that only one of the four successor states receives nonzero weight, as is seen in figure 4c by taking  $\theta$  to be zero.

---

<sup>4</sup>If a gate has particles at both switch-wire inputs, this formulation allows some successor states that have two particles at the same position. However, that does not occur in any of the examples in this paper.

## 5 Quantum-like properties of quantish physics

The laws of quantish physics, like the laws of U1 and U2, are *local*. The destinations (and new attribute-bit values) of a particle at a switch wire of some gate in some classical state depend only on the particle’s current attribute-bit value, the gate’s measurement vector, and whether there is a particle at the control wire of the same gate in the same classical state. Similarly, the destination and attribute bit of a control-wire particle at some gate in some state depend only on that gate and that particle in that state.

Thus, there is no action at a distance with respect to circuit-topology space, or with respect to configuration space. And, of course, the quantish-physics laws are entirely deterministic. I now demonstrate that these local, deterministic laws support phenomena like those of the real quantum world: apparent indeterminacy of quantum states, interference of superposed outcomes, and interference-observation duality.

### 5.1 Apparently nondeterministic outcomes

In figure 5a, particle  $p_1$  “splits” at  $g_1$  (as in figure 4a), and is then observed at gates  $g_2$  and  $g_3$  (as in figure 3). (Here and throughout, when I show gates wired in series, inputs shown at gates later in the series are synchronized, by circuitry not shown, to arrive there simultaneously with inputs from earlier in the series. Thus, in figure 5,  $p_2$  and  $p_3$  arrive at gates  $g_2$  and  $g_3$  simultaneously with  $p_1$ .)

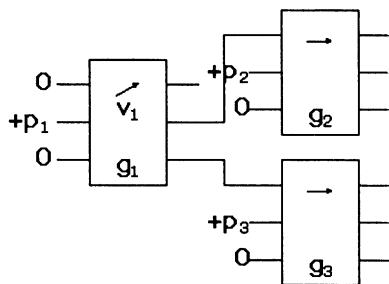

Figure 5: Particles  $p_2$  and  $p_3$  observe  $p_1$ .

In those states that have  $p_1$  arriving at  $g_2$ ’s control wire,  $p_2$  crosses over (without splitting, given its + attribute bit and  $g_2$ ’s  $(1, 0)$  measurement vector); and  $p_3$  passes straight across, since states in which  $p_1$  arrives at  $g_2$  do not have  $p_1$  arriving at  $g_3$ . Similarly, in states in which  $p_1$  does arrive at  $g_3$ ,  $p_3$  crosses over, and  $p_2$  passes straight across. Thus, as in figure 3, the two observations are consistent:  $p_1$  is always observed at exactly one of its two possible destinations.

From within the quantish universe, then, it appears that  $p_1$  arrives at one gate or the other, but never both. Every successor state is consistent with there being just one destination; and although different successors with different destinations remain in superposition, they have no effect on one another (unless they later reconverge in configuration space as addressed in the next section). However,

unless  $g_1$ 's measurement vector  $v_1$  is  $(0, 1)$  or  $(1, 0)$ , *which* destination the particle will have cannot be specified in advance—because, in reality, it will have both destinations, notwithstanding appearances to the contrary from the point of view of any superposed classical state in the quantish universe. Thus, the outcome appears from within the quantish universe to be nondeterministic.

Moreover, it is possible to quantify the nondeterminism by interpreting each state's weight as the square root of the probability that the universe is in that state, as noted above. The probability that the particle passes straight across is the fraction of the predecessor state's probability that moves to successor states in which the particle passes straight across (and similarly for the probability of crossing over). These probabilities are  $\cos^2 \theta$  and  $\sin^2 \theta$  respectively, with  $\theta$  defined as in the previous section with respect to  $g_1$ 's measurement vector  $v_1$ .

The apparatus of figure 3 permits observation of a particle's position; and if  $v_1$  were  $(1, 0)$ , the circuitry would also allow the particle's attribute bit to be observed. With a measurement vector of  $(1, 0)$ , gate  $g_1$  sends  $p_1$  entirely to  $g_2$  if  $p_1$ 's attribute is  $+$ ; there,  $p_2$  observes  $p_1$ . If the particle's attribute is  $-$ ,  $p_1$  goes entirely to  $g_3$ , and is observed there by  $p_3$ . If the particle is in a superposition of states with both attribute-bit values, the particle arrives (in different successor states) at  $g_2$  and at  $g_3$ .

## 5.2 Interference of superposed states

Having seemingly nondeterministic outcomes is a step towards having quantum-like phenomena, but it falls short of the fundamental quantum duality, which requires superposed states that mutually interfere, unless distinguished from one another by observation. I now demonstrate such interference in the quantish physics model.

In figure 6a, gates  $g_1$  and  $g_2$  both have measurement vector  $(1, 1)$ . When  $p_1$  arrives at  $g_1$ , the initial weight  $c_1$  in figure 6b divides among the four successor states shown, each receiving a weight of half  $c_1$ 's magnitude. (The configuration-space cross-sections in figures 6b and c have  $p_1$ 's attribute as their horizontal dimension,  $p_1$ 's position as their vertical dimension.) There are two successor states in which  $p_1$  passes straight across (one with attribute  $+$  the other  $-$ ), and two in which it crosses over, again with each attribute value.

Rather than observing the split particle as in figure 5, the circuit in figure 6a arranges to *re-merge* the particle. That is, each of the four successor states itself splits into four states when the particle passes through  $g_2$ . However, there are not sixteen distinct resulting states, but rather only four, each with four distinct predecessors. Figure 6d shows the quantum successor states of  $c_{2a}$ ,  $c_{2b}$ ,  $c_{3a}$ , and  $c_{3b}$  according to the weight-splitting rule illustrated in figure 4; figure 6c shows the sum of those four quantum successors.

As seen in figure 6c, the sixteen contributed weights—each of one fourth  $c_1$ 's magnitude—add to zero at three of those four successor points. At the remaining point—in which  $p_1$  emerges at  $g_2$ 's upper switch wire  $w_{2b}$ , with a  $+$  attribute bit—the contributed weights combine to reconstruct the original weight,  $c_1$ . Thus,  $p_1$

emerges only from  $g_1$ 's upper switch wire, and with its original attribute-bit value. Gate  $g_3$ , with vector  $(1, 0)$ , then tests  $p_1$ 's attribute bit, bringing  $p_1$  to  $w_{2c}$ , since its attribute-bit value is  $+$ ; had the bit been minus,  $p_1$  would have arrived instead at  $w_{3c}$ .

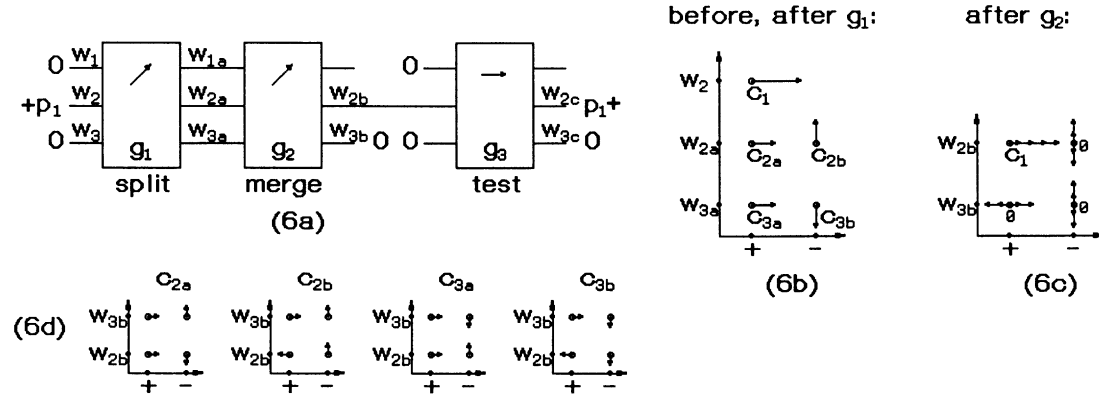

Figure 6: Superposed states re-merge and interfere.

We are now in a position to see the effects of superposed states' interference in the quantish physics model. Compare figure 6 with the similar figure 7; in figure 7, one of  $p_1$ 's paths diverts innocuously away from  $g_2$ . (The boxes labeled  $D$  are *delay gates*. Each is an ordinary Fredkin gate. The wire shown is the control wire; not shown are two  $0$ 's on the switch wires.) In figure 7b, the original state (with weight  $c_1$ ) splits, as before, into four successor states, two of which have  $p_1$  at  $g_2$ 's upper switch-wire input  $w_{2a}$ .

Next, due to  $p_1$  passing through  $g_2$ , those two states divide their weights, as before, among four successor states. But the other two states, in which  $p_1$  is at  $w_{3a}$ , no longer contribute weight to those same four successors. And without those contributions exerting canceling or reinforcing influence, there remain nonzero-weighted successor states in which  $p_1$  emerges from  $g_2$ 's upper switch-wire output  $w_{2b}$  with minus-attribute, as well as with plus-attribute (figure 7c). Thus, in turn, there are nonzero-weighted successor states in which  $p_1$  emerges from  $g_3$  at  $w_{3c}$ , as well as at  $w_{2c}$ ; as seen from within the quantish universe,  $p_1$  emerges unpredictably from one or the other of  $g_3$ 's switch-wire outputs.

Contrasting figures 6 and 7, we see a genuine quantum interference phenomenon. Figure 6, compared to figure 7, provides an additional path by which  $p_1$  might reach  $g_3$ 's lower switch-wire output  $w_{3c}$ ; yet  $p_1$  emerges there less often (in fact, never) with the extra path provided than without that path. This is inexplicable on the assumption—which otherwise seems correct, from within the quantish universe, as seen in the previous section—that  $p_1$  is a particle-like entity that exists at just one wire at a time. Only by acknowledging the simultaneous reality of  $p_1$ 's superposed states at  $w_{2a}$  and  $w_{3a}$  can we (or any observer embodied in the quantish universe) account for the possibility that those states can interfere with one another, when a path is provided to convey the interfering influence. The interference is achieved, of course, by the addition of complex weights at common successor states.

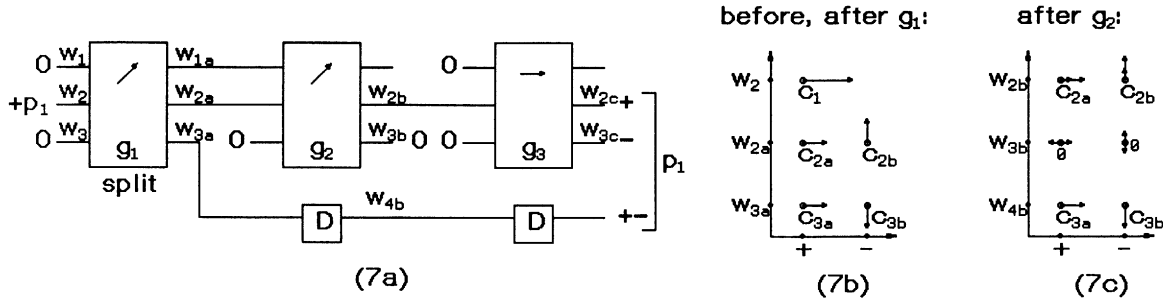

Figure 7: One path diverts from re-merging, removing the interference at  $g_2$ .

The setup of figure 6 is analogous to the real-world double-slit experiment, in which a particle is in a superposition of states (passing through slit 1, or slit 2). *Destructive* interference among the superposed states reduces the likelihood of the particle’s arrival at certain points along the backdrop; but blocking one of the two possible paths also blocks that interference. (The two slits are like the two switch-wire inputs to  $g_2$  in figures 6 and 7; the diversion away from the lower input to  $g_2$  in figure 7 is like blocking one of the two slits.) Less dramatically paradoxically, *constructive* interference increases the probability of arrival at certain points above what the sum of the two single-slit curves would predict; similarly, in figure 6, the frequency of arrival at the upper switch wire  $w_{2c}$  increases due to the additional path.<sup>5</sup>

### 5.3 Blocking interference via observation

If inhabitants of a quantish physics universe perform the above experiments, they face the same apparent paradox as physicists in the real universe. When a “split” particle is observed as in figure 5, the results consistently and unambiguously show that the particle reached one destination or the other, but not both. Yet, comparing the behavior of the figure 6 circuit with that of figure 7, there is a demonstrable interference effect which is explicable only on the assumption that the particle indeed reaches both destinations (as we privileged observers of configuration space, looking from outside the quantish universe, know to be the case).

Let us sharpen the “paradox” further. Suppose inhabitants of the quantish universe try to observe  $p_1$  on its way to  $g_2$ —that is, after its path splits and before it re-merges. Figure 8 shows a setup where  $p_2$ , at gate  $g_4$ , crosses over or not depending on whether  $p_1$  reaches  $g_4$ . Particle  $p_1$  is then routed into  $g_2$  as before; delay gates have been inserted at the other two paths to  $g_2$  to maintain synchronization. Note that  $p_1$  is unaltered by this observation; classically, then, the observation should not change the outcome of the experiment. But in quantum

<sup>5</sup> We might also take this setup as an analog of the Stern-Gerlach experiment (see, for example, [Cohen-Tannoudji]). Particle  $p_1$ ’s attribute bit is analogous to a real-world particle’s spin;  $g_1$  and  $g_2$  together correspond to a Stern-Gerlach module that diverges and then reconverges particles’ paths according to their spin with respect to a certain axis (analogous to the gates’ common measurement vector).



physics, making an observation to distinguish two superposed states blocks any subsequent interference between those states. And that is just what happens here.

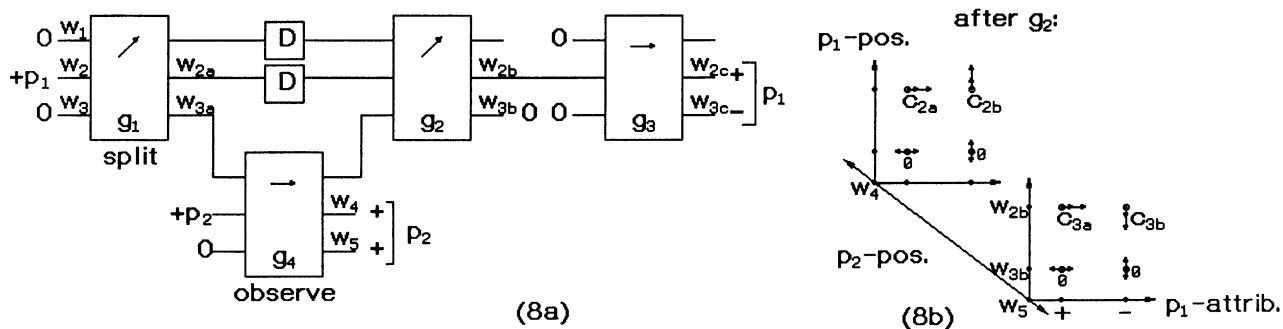

Figure 8: An observation circumvents subsequent interference.

We find the same bizarre result as in the real universe when we observe which slit the electron came through: the interference disappears. The configuration-space explanation of this phenomenon is straightforward (compare figure 8b with figure 6c). The set of successors to the states in which  $p_1$  enters  $g_2$ 's upper switch wire is now entirely disjoint from the set of successors of the other states, since the states in the first set show  $p_2$  having passed straight across (not having observed  $p_1$ ), and the other states show  $p_2$  having crossed over (in response to  $p_1$ ). Thus, as a result of the observation that distinguishes between the two sets of states, there is no convergence, and hence no interference, between the two sets of states. The outcome, as seen from any of the states, is just as though  $p_1$  had traversed just one wire or the other (as the classical view would have it), but not both.

Note, by the way, that even a so-called *negative* observation results in the absence of interference. In the states in which  $p_1$  does not reach  $g_4$ ,  $p_1$  does not interact with  $p_2$ . But that very absence of interaction—that is, a negative observation—is fully informative as to  $p_1$ 's whereabouts: if  $p_2$  doesn't cross over,  $p_1$  must be on  $g_1$ 's upper switch-wire output. Accordingly, even the states in which the observation at  $g_4$  was negative have successors that exhibit no interference, as shown by the fact that  $p_1$  emerges from  $g_3$ 's lower switch wire with the expected nonzero frequency following a negative observation at  $g_4$ .

Renninger (see [deBroglie64]) cites negative observation to demonstrate the incorrectness of one naive account of eliminating interference via observation—the account that attributes this elimination to the inevitable disturbance of an observed entity by the observer. But a negative observation can cause no such disturbance (since there is no interaction at all), yet the interference disappears all the same. Looking at the situation from configuration space, this is just as we would expect: the fact that  $p_2$  encounters  $p_1$  in *one* of two superposed states makes those two states differ along their  $p_2$ -position dimension, moving them out of “interference range” of one another, thus circumventing interference in both states.

At this point, the quantum interference-observation duality becomes a comprehensible—indeed, deducible—property of the quantish universe. The quantish

physical laws say that where a classical state's weight moves to in configuration space is determined only by that state; other superposed states are irrelevant. Therefore, states separated along some particle-attribute dimension in configuration space can interfere *only* by reconverging to the same point in configuration space (as happens, for example, in figure 6). Any observation that distinguishes the superposed states must (as in figure 8) create a corresponding separation along a distinct dimension in configuration space (and any additional such observations, or any observations of the observations, compound the separation along still other dimensions). Then, reversing the original separation creates no interference, since there is still separation in one or more other dimensions. (But if those separations are also reversed, interference is reestablished, as in figure 9.) Thus, given the laws of quantish physics, there is a *necessary* tradeoff between an interfering superposition, and any observation that distinguishes among the superposed states.

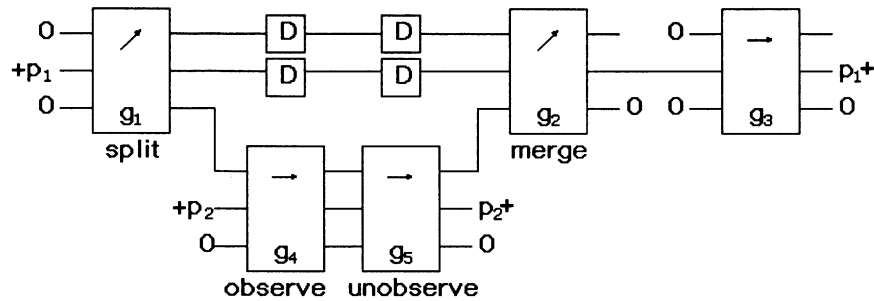

Figure 9: At  $g_5$ ,  $p_2$  always emerges at the upper switch wire, erasing the observation made at  $g_4$  and reestablishing interference at  $g_2$ , as detected at  $g_3$ .

Thus the quantish universe—like the real quantum universe—behaves classically to just the extent that we try to catch it in the act of behaving otherwise. (The following two sections show that the quantish formalism also supports analogs of Heisenberg's uncertainty principle, and of the EPR experiment.) The quantish physics formalism shows how such behavior can be exhibited by deterministic mechanical laws that support only local interactions, and that have no peculiarity with respect to there being a definite, objective, observer-independent (quantum) state of the universe.

## 5.4 A geometric interpretation of attribute bits

As seen in section 4, attribute-bit values  $+$  and  $-$  may be regarded as corresponding to vectors  $(1, 0)$  and  $(0, 1)$  in the same two-dimensional space as gates' measurement vectors. Figure 10 recapitulates figure 4, with *attribute vectors*  $v_0$ ,  $v_2$ , and  $v_3$  appearing in figure 10a in place of the attribute-bit designations of figure 4a. Of course, the laws of quantish physics are formulated in terms of attribute bits, not attribute vectors; but attribute vectors, as defined just below, have properties that help elucidate the quantish laws.

The designation of attribute vectors is as follows. Consider a pair of states that differ only in the attribute-bit value that they assign to some particle  $p$ ; all particle positions, and all other attribute values, are the same in both states. Let us say that two such states are  $p$ -neighbors. Thus, in figure 10d, the two states with weights  $c_{2a}$  and  $c_{2b}$  are  $p_1$ -neighbors, as are the states weighted  $c_{3a}$  and  $c_{3b}$ . Let  $c_+$  be the weight of the  $p$ -neighbor  $S_+$  in which  $p$  has a + attribute bit; and  $c_-$  is the weight of the  $p$ -neighbor  $S_-$  in which  $p$  has a - attribute bit.

Particle  $p$ 's attribute vector  $v$  at that pair of  $p$ -neighbors is defined to be  $(\text{Re}(c), \text{Im}(c))$ , where  $c = (c_+ + c_-) \frac{|c_+|}{c_+}$ ; in other words,  $v$  is the sum of the neighbors' weights, taken as a vector in the complex plane, and normalized so that  $c_+$  corresponds to  $(|c_+|, 0)$ . Or, if  $c_+$  is zero, then we define  $v$  to be  $(0, |c_-|)$ .

Hence, in figure 10, the  $p_1$  neighbors in which  $p_1$  has passed straight across to  $w_{2a}$  assign to  $p_1$  the attribute vector  $v_2$ , relative to weight  $c_1$ ; and the  $p_1$ -neighbors in which  $p_1$  has crossed over assign to  $p_1$  the attribute vector  $v_3$ , relative to  $c_1$ . Attribute vector  $v_2$  is parallel to the measurement vector  $v_1$ , and  $v_3$  is perpendicular.

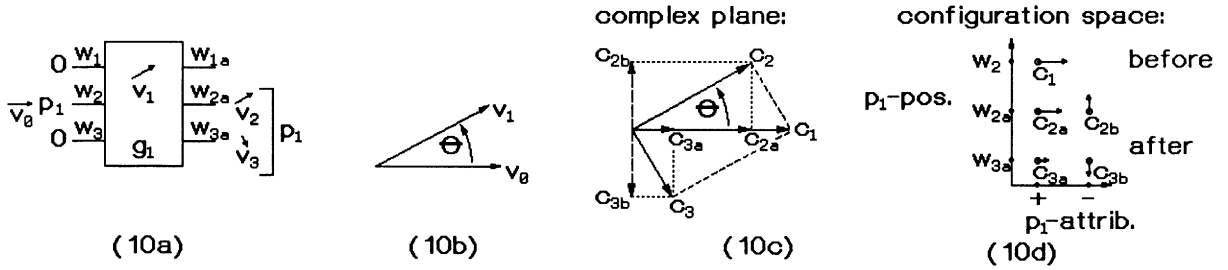

Figure 10: A gate splits a particle's attribute vector into components parallel and perpendicular to the gate's measurement vector.

It is clear from figure 10 that if a  $p$ 's attribute vector is parallel to  $(1, 0)$  or to  $(0, 1)$ —that is, if only one of the  $p$ -neighbors has a nonzero weight—then a gate's switch wire will split  $p$ 's vector into vectors parallel and perpendicular to the gate's measurement vector.<sup>6</sup> The parallel vector passes straight across and the perpendicular vector crosses over, assuming no control-wire particle; otherwise, vice versa. The parallel attribute vector ensues with probability measure  $\cos^2 \theta$ , the perpendicular vector with probability measure  $\sin^2 \theta$ , where  $\theta$  is the angle between the particle's original attribute vector and the gate's measurement vector.

More generally, even if  $p$ 's attribute vector is oblique—that is, if both  $p$ -neighbors have nonzero weights—it still splits into vectors parallel and perpendicular to the measurement vector, crossing over or not according to the control

<sup>6</sup>In fact, the attribute vector splits into two vectors, one that is plus or minus the attribute's projection onto the measurement vector, the other plus or minus the attribute's projection onto a line perpendicular to the measurement vector. The *plus or minus* is due to the fact that attribute vectors can only be in the two rightmost two quadrants of the plane (a straightforward consequence of the above definition); a projection into the leftmost quadrants yields the inverse of that projection as the new vector.

wire (again with probability measures  $\cos^2 \theta$  and  $\sin^2 \theta$ ).<sup>7</sup> The reader may verify that this fact follows from the linearity of quantish state succession; to put it very briefly, the sum of the neighbors' weights' decompositions into orthogonal components equals the decomposition of the neighbors' weights' sum, and the attribute vectors add correspondingly.

Furthermore, when a split particle reconverges to a single position (as at gate  $g_2$  of figure 6a), its new attribute vector equals its attribute vector prior to the split, because the reconstruction of the original neighboring weights from their orthogonal components ensures the reconstruction of the corresponding attribute vector. Thus, in figure 6a, the component of  $p_1$ 's attribute vector that is parallel to the measurement vector proceeds straight across  $g_1$  and  $g_2$ , while the perpendicular component crosses over at  $g_1$  and then back again at  $g_2$ , recombining with the parallel component to reconstruct the original vector.

Note, in particular, that if a particle's attribute vector is parallel to a gate's measurement vector, the gate treats the particle as would a U1 or U2 gate: the particle entirely crosses over or not depending on the presence or absence of a control-wire particle. This fact generalizes the observation in section 4 that a gate with measurement vector  $(1, 0)$  produces only one nonzero-weighted successor for a state in which the switch-wire particle has a  $+$  attribute-bit value, as in figures 11a and b. When both  $p_1$ -neighbors have nonzero weight (as in figure 11c), each of the neighbors has four nonzero-weighted successors; both neighbors have the same four successors as one another. As shown in figure 11d (and as the reader may verify by applying the state-splitting rule), the contributed weights sum to zero in the states corresponding to the perpendicular component, and sum to the original weights  $c_{1a}$  and  $c_{1b}$  in the states corresponding to the parallel component, thus reconstructing the original attribute vector.

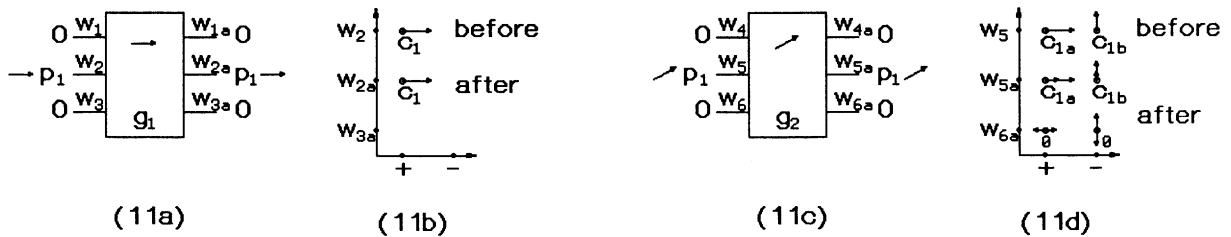

Figure 11: A particle's attribute vector parallels a gate's measurement vector, so no splitting occurs.

In  $p$ -neighbors  $S_+$  and  $S_-$ , we can say that  $p$  has a *definite value* with respect to some measurement vector  $v_1$  if its attribute vector is parallel or perpendicular to  $v_1$ . As just seen, if particle  $p$  enters a gate's switch wire, and has a definite

<sup>7</sup>Because of this uniformity, the vectors  $(1,0)$  and  $(0,1)$  that correspond to the  $+$  and  $-$  bits turn out not to play a detectable privileged role in quantish physics—inside the quantish universe, there is no experiment whose outcome distinguishes which orthonormal basis set for attribute vectors corresponds to the  $+$  and  $-$  attribute-bit values.

value with respect to the gate’s measurement vector, no further state-splitting results; the outcome does not appear to be non-deterministic. But a definite value with respect to a given measurement vector is not definite with respect to a different, oblique vector. This fact translates Heisenberg’s uncertainty principle into the quantish universe: no particle can have a definite value with respect to all measurement vectors at once. There are always measurement vectors with respect to which there is an apparent uncertainty—actually, a multiplicity—of outcomes.<sup>8</sup>

## 5.5 Coupled particles: the EPR experiment

As a final example, this section presents the quantish parallel of the crucial Einstein-Podolsky-Rosen (EPR) experiment [Einstein35]. The experiment disproves all so-called *hidden-variable* accounts, which postulate that the apparent indeterminacy of quantum phenomena is due to underlying unknown attributes, each with a definite, unique value.

In figure 12,  $p_1$  and  $p_2$  both start with attribute vectors parallel to  $(1, 1)$ , as given by the quantum state of figure 12a, which shows four superposed states with orthogonal weights of equal magnitude. In the circuit of figure 12b,  $p_3$  emerges from  $g_4$  at the upper switch wire if and only if  $p_1$  and  $p_2$  both have a + attribute (in which case  $p_3$  crosses over at  $g_3$ , and again at  $g_4$ ), or both have a - attribute (in which case  $p_3$  crosses over at neither gate).

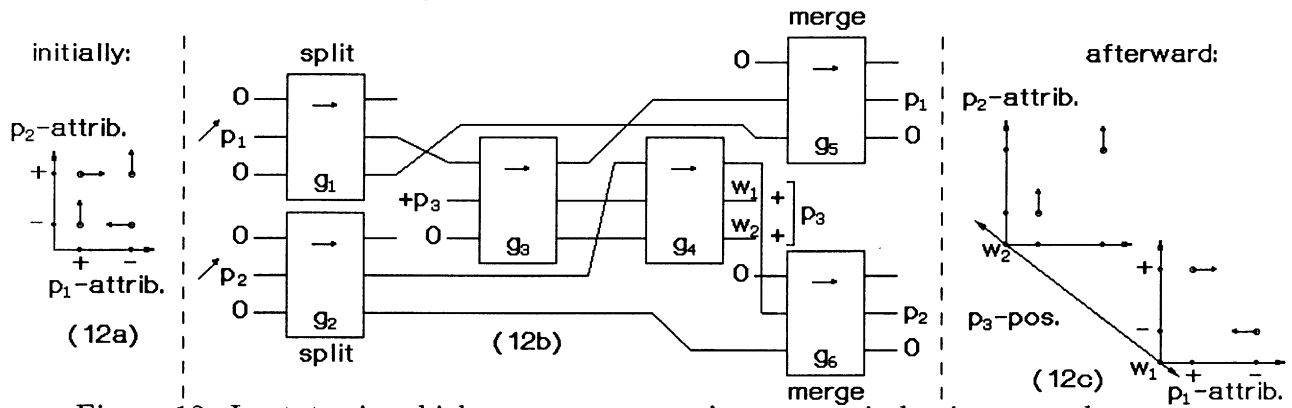

Figure 12: In states in which  $p_3$  emerges at  $g_4$ ’s upper switch wire,  $p_1$  and  $p_2$  are coupled.

Figure 12c shows a cross-section of configuration space with the resulting weights. Let us say that  $p_1$  and  $p_2$  are *coupled* in the two superposed states in which  $p_3$  has arrived at the upper wire  $w_1$ —oppositely-weighted states in which

<sup>8</sup>However, the quantish world, in contrast with real physics, allows definite position but has no analog of momentum. Thus, in quantish physics, all “uncertainty” (superposition) with respect to position can be eliminated without introducing any complementary superposition. The idea of quantum superposition, with interference-observation duality, is therefore separable from the uncertainty-principle requirement that there be some minimal, ineliminable such superposition. The quantish model does have ineliminable superposition with respect to attribute vectors, but not with respect to position.

$p_1$  and  $p_2$  have the same attribute-bit value, both + in one state and both - in the other.

Coupled particles exhibit a remarkable property. In figure 13a, one of the coupled particles,  $p_1$ , now enters a switch wire of gate  $g_7$  with vector  $v_1$ ;  $p_1$  emerges at the upper switch wire  $w_3$  with an attribute vector parallel to  $v_1$ , or at the lower wire  $w_4$  with a perpendicular vector. Figure 13b shows the resulting superposition in a cross-section of configuration space (taken at coordinate  $w_1$  on the  $p_3$ -position axis—that is, looking only at the portion of configuration space in which  $p_1$  and  $p_2$  have coupled). As the reader may verify, the states in which  $p_1$  arrives at  $w_3$  assign attribute vectors parallel to  $v_1$  to *both*  $p_1$  and  $p_2$ ; and the states in which  $p_1$  arrives at  $w_4$  assign to both particles attribute vectors perpendicular to  $v_1$ .

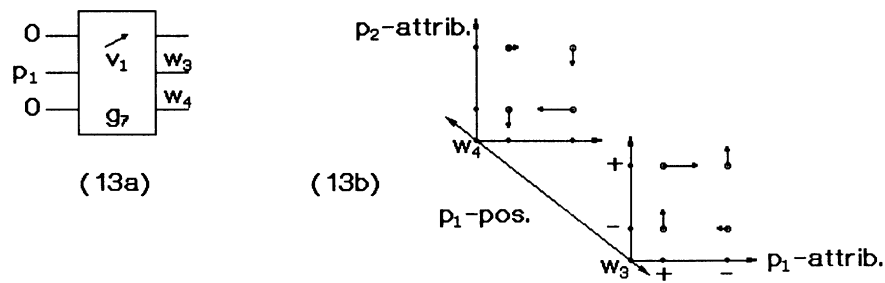

Figure 13: Decomposing a coupled particle’s attribute vector correspondingly decomposes the other particle’s vector.

Proponents of a classical world-view—a view that denies the reality of multiple superposed states of the universe—might try to explain the correspondence between the coupled pair’s two attribute vectors by claiming that each particle already has (prior to any measurement) a single, definite value with respect to each possible measurement vector—a *hidden-variable* explanation. Then, the obvious explanation for the correspondence is that both members of each coupled pair simply start out having the same definite value as one another for each possible measurement vector.

From our privileged vantage point, we know that the hidden-variable account is false; we see that configuration space provides a superposition of correlated values for the coupled particles, not a single definite value for each particle. But can the hidden-variable account of the paired vectors’ correspondence be disproved from *within* the quantish universe? A subtle theorem proved by Bell [Bell64] indeed allows one to show from within the quantish universe that the hidden-variable account must be wrong.

Let us say that  $g_7$  measures  $p_1$  with respect to measurement vector  $v_1$ . Suppose, at another gate, we (subsequently, or simultaneously) measure  $p_2$  with respect to the same vector  $v_1$ . Because of the attribute-vector correspondence noted above the two measurements will have the same outcome—in any resulting state,  $p_1$  and  $p_2$  will both have emerged at the upper switch-wire outputs of the two measuring gates, or else will both have emerged at the lower wires. More generally, if  $p_2$  is measured instead with respect to some other vector  $v_2$ , the two measurements

have the same outcome with apparent probability  $\cos^2 \theta$  (hence have an apparent discrepancy rate of  $\sin^2 \theta$ ), where  $\theta$  is the angle from  $v_1$  to  $v_2$  (and hence the angle by which  $p_2$  misses having a definite value with respect to  $v_2$ ).

Bell's theorem states that, if each pair of coupled particles already has a single definite value for each of three arbitrary measurement vectors  $v_a$ ,  $v_b$ , and  $v_c$ , and if we perform measurements on many pairs of coupled particles, then the discrepancy between  $v_a$  and  $v_c$  measurements (that is, the discrepancy rate over trials in which one coupled particle is measured with respect to  $v_a$ , the other with respect to  $v_c$ ) cannot exceed the sum of the discrepancy between  $v_a$  and  $v_b$  measurements and the discrepancy between  $v_b$  and  $v_c$  measurements; this is *Bell's inequality*. The inequality follows simply from the fact that any particle with a different value with respect to  $v_a$  than with respect to  $v_c$  must also have a difference between its  $v_a$  and  $v_b$  values or between its  $v_b$  and  $v_c$  values (since its  $v_b$  value cannot match both its  $v_a$  value and its  $v_c$  value if its  $v_a$  and  $v_c$  values differ).

Let us take  $v_a$  to be  $(1, 0)$ ,  $v_b$  to be  $(\cos \frac{\pi}{8}, \sin \frac{\pi}{8})$ , and  $v_c$  to be  $(1, 1)$ . If we perform the experiments in the quantish universe, we will find that the discrepancy between  $v_a$  and  $v_c$  is  $\sin^2 \frac{\pi}{4} = .5$ , and the discrepancy between  $v_a$  and  $v_b$ , and also between  $v_b$  and  $v_c$ , is  $\sin^2 \frac{\pi}{8}$ , which is about 0.146. This clearly violates Bell's inequality.

Therefore, the observed correlation between paired particles' measurements with respect to vectors  $(1, 0)$ ,  $(\cos \frac{\pi}{8}, \sin \frac{\pi}{8})$ , and  $(1, 1)$  cannot possibly be explained by saying that for each pair of particles, there was already, prior to measurement, a single definite value for each possible measurement vector (a value shared by both members of the pair). If one were to deny the reality of multiple superposed states of the universe, the only remaining way to account for the observed correlation among the coupled particles' measurements with respect to the three vectors would be to postulate that the outcome of measuring one particle is—by some unknown, unexplained mechanism—communicated to the other coupled particle, in such a way as to force the other particle into the same value with respect to whatever measurement vector was used.

In fact, of course, no such mechanism is involved, nor could there be, given quantish physical laws, when there is no circuitry between the two measuring gates to communicate the outcome from one gate to the other. The quantish physics model instead accounts for the correlation by saying that there is a superposition of appropriately weighted entire classical states of the universe, and each superposed state shows the coupled particles having identical attributes. Thus, the correlation is explained not by communication at the time of measurement, but by the fact that the particles start out with corresponding values, as in the naive classical account. Here, however, there is not just a single universe state in which the coupled particles have the same attribute, but rather a superposition of such states. These states' interference creates correlations that would be impossible, by Bell's theorem, if there were only one such state.

The foregoing is adapted from the proposed EPR experiment, later carried

out in modified form by several investigators (e.g. [Aspect82]).<sup>9</sup> These experiments reveal correlations which Bell’s analysis proves impossible if each particle already has a single definite value with respect to each possible measurement, and if the two particles cannot communicate with one another at the moment of measurement. Since the two measurements can be performed arbitrarily far from one another, and arbitrarily closely in time, physicists who reject the reality of multiple superposed states of the universe are thereby forced to postulate an unexplained, faster-than-light interaction. Moreover, this interaction has the curious property that it cannot be harnessed for the transmission of information from one measurement site to the other—though this curiosity is just what one would expect were there not, in fact, an interaction, but rather just a manifestation of a preestablished correlation.

## 6 Multiple worlds or quantum collapse?

Quantish physics, though comparatively simple, presents a deep analogy to true quantum physics. Consequently, one can envision an Everett vs. Copenhagen debate among physicists embodied in the quantish universe; the resulting insights are equally applicable to real quantum mechanics. Let us consider what the Copenhagenists and Everettists would say about their quantish world.

The Everettists describe their universe by the formal model just presented here; in this model, distinguishing the elements of a superposition by making an observation can be said, loosely speaking, to split the universe into two branches, one for each outcome of the observation. Everettists regard the distribution of weights in configuration space as a real physical entity—indeed, the *only* physical entity, the one that implements all others.

The Copenhagenists accept the same formal model as a description of any part of their universe between observations. But when they make an observation, they consider it obvious that only one outcome has occurred (they plainly see just one outcome); hence, they say that the superposition of states given by the formal model collapses, leaving just one element of the superposition. Since there is only one “real” state, the other states were not real, but just corresponded to “possibilities”, just one of which becomes real when observed. Note that if the other states had been real, the collapse would have to annihilate all but one of them. That event, of course, is not predicted by the formal model (nor is any abrupt transition from “possible” to “actual”); instead, the model predicts a moving-apart (in configuration space) of superposed states that would look, from within each, like the disappearance of the others.

In an obvious sense, the formal model is the most straightforward description of the universe compatible with experimental results. Indeed, the most straightforward description of the Copenhagen interpretation invokes the same formal

---

<sup>9</sup>In the real-world versions of the experiment, coupled particles’ attributes are exactly opposite one another, rather than identical, as here; but that difference is inessential for present purposes.



model, but adds a complication, the quantum collapse, which renders the theory incomplete and ambiguous, and for which there is no evidence:

- The theory becomes incomplete because it cannot describe a quantum state of some portion of the universe, except relative to some other portion that embodies an observer; the theory cannot, in principle, describe the quantum state of the universe as a whole, and give laws for the evolution of that state. The Everett formulation can and does.
- The theory is ambiguous as to what sort of physical interaction constitutes a superposition-collapsing observation. Yet the theory makes different predictions depending on whether such an observation has occurred: in particular, if the observation is later “reversed”, reconverging the superposed states (as in figure 9 in section 5.3), interference occurs if the superposition is intact, but cannot occur if the superposition has collapsed, leaving nothing to interfere with.
- Whenever such reconvergence is achieved experimentally, interference indeed occurs, demonstrating that the superposition has not collapsed.

Not only is the postulated collapse gratuitous, and incompletely and ambiguously specified, but furthermore, all of the problematic features of quantum physics—the apparent non-objectivity of the state of the universe, apparent nonlocality of the effects of a measurement, and apparent nondeterminism—result from postulating the collapse. Since the formal model already accounts for all the facts, what motivates adding the quantum collapse?

Here are three arguments for postulating the quantum collapse. Elements of these arguments appear in the writings of physicists (in the real universe) who oppose the Everett interpretation. Each of these arguments has persuasive power, but is ultimately flawed.

1) *The argument from non-interaction.*

Following a macroscopic quantum observation—by a person, say, or a laboratory instrument—universe branches may diverge irreversibly (thermodynamically irreversibly: it is astronomically unlikely that every microscopic manifestation of the observation will be undone, leaving no trace of the observation). If there is a branch of the universe with which we can never interact, we may ask what justifies calling it real. We would not, after all, acknowledge the reality of some arbitrary, fanciful entity that putatively sits in our midst but is forever impossible to detect.

But, as argued above, other branches of the universe do interact with ours; quantum interference *is* that interaction. And the only reasonable formalism that accords with the evidence—that guarantees the quantum interference-observation duality, explaining the apparent hide-and-seek game—postulates superpositions in configuration space, not just physical space; that is, the formalism includes coexisting states of the universe, not simply coexisting versions of various particles in the same universe state.

True, when a practically-irreversible quantum observation occurs, a previously interacting branch of the universe moves forever “beyond range” of further interaction. But to say that it thereby ceases to exist makes no more sense than to deny the continued existence of an object that has become so distant that we cannot hope ever to detect it again. Such a stance is sheer solipsism. Demonstrably real things do not cease to exist merely because they move too far away—in physical space, or in configuration space—for us to be likely to detect them anymore.

Moreover, as argued in a provocative paper by [Deutsch86], radically divergent branches of the universe can, in fact, reconverge. One can construct a “quantum computer” in which arbitrarily complex observations are erasable in the manner of figure 9; the underlying principle is no different than that responsible for ordinary quantum interference. If the apparent quantum collapse really entailed the disappearance of all but one superposed state, there would be nothing left to reconverge with when an observation was undone. Thus, to account for reconvergence, Copenhagenists have to deny that a later-undone observation was in fact an observation, even though it would have been were it not going to be undone. Since Copenhagenists are unconstrained by any definite principle as to what constitutes an observation, they can make this denial without actual contradiction—but not with much credibility.

### 2) *The argument from immensity.*

The configuration-space universe is very big. It seems somehow counterintuitively wasteful for there to be astronomically many versions of the world when a single one would do just as well. (I must confess to feeling the force of this intuition myself—though curiously, my intuition balks more at the the size of a perhaps-finite configuration-space universe than at a perhaps-infinite classical universe.) But this intuition can only be an expression of naive anthropocentrism: only if the “purpose” of the universe were to support middle-sized objects (such as ourselves) would it be surprising to find that things are much more complicated than that purpose requires. It would be as plausible to deny the reality of atoms on the grounds that unimaginably many of *them* are required to explain simple, everyday phenomena.

Of course, parsimony is a legitimate criterion for judging theories. But what counts is parsimony of explanatory concepts, not (or not as much) parsimony of the objects being explained. If a compact set of laws accurately describes a universe of vast intricacy, so much the better for those laws. One should not posit an extra kind of event in the universe—especially an event for which there is no evidence, an event that has no precise description and that violates locality, determinism, and the objective nature of reality—simply because the consequent universe would be much smaller.

### 3) *The argument from unitary consciousness.*

Some persons can accept the immensity of the quantum superposition of universe branches, but reject the idea that they themselves might “split” into multiple

versions. The paradox seems to be: when I look at an apparatus that measures the outcome of a quantum event, if the universe then splits into two branches, with two versions of myself, which version of myself do “I” become? Each version next sees a different state of the apparatus; which is “my” next experience? Clearly not both (I never see both outcomes together); but if only one, then isn’t that the only “real” outcome?

This is indeed paradoxical if one conceives of time flowing forward, with one’s consciousness flowing along with it from temporal version to temporal version of oneself. Alternatively, though, one might acknowledge that there is no such flow. Everything is just sitting statically in spacetime; each next temporal version of oneself includes memories of previous versions, and experiences the illusion of a unitary consciousness having been passed from the previous versions. From this point of view, there is no paradox if multiple subsequent versions, instead of just one, happen to share this illusion.

I will not argue here for this view. For present purposes, it suffices to note that the consciousness objection to universe-splitting has nothing to do with physics, and everything to do with one’s conception of consciousness.<sup>10</sup> Those who accept that consciousness is a mechanical phenomenon tend not to find consciousness-splitting paradoxical. But our culture inherits the tradition of Cartesian dualism, which encourages a mystical view of the mind while promoting a mechanistic view of physics. Precisely at the point where universe branches diverge for a quantum observation made by a conscious observer, some nonmechanical concepts of consciousness come into direct conflict with physical principles. For physicists such as von Neumann, it is the physical principles that yield: to accommodate his unwillingness to accept a splitting of mind, von Neumann denied the entire splitting of the physical world, postulating instead a quantum collapse at just the point where conscious observation occurs.

In summary, then, the Everett interpretation of quantum mechanics merely takes seriously the formalism that accords with our (experimental) experience; Everettists take the formalism to describe a physical reality. In this interpretation, there is no such event as the collapse of the superposition; superposed states all persist, but may move out of range of interacting with one another. The resulting physical system is straightforwardly objective, mechanical, local, and deterministic.

There is no good reason to postulate the quantum collapse. But there are several seemingly good reasons to do so, at least one of which is deeply rooted in a major point of confusion (Cartesian dualism) in our philosophical tradition. The force of these flawed reasons may explain why most physicists do postulate the collapse.

---

<sup>10</sup>Philosophers grapple with paradoxes that concern a hypothetical science fiction device for disassembling a person’s atoms and assembling an exact copy at a remote location. If *two* such copies are assembled, the same questions arise as posed here by split universes (see [Nozick81], chapter 1).

## 7 Conclusion

Quantish physics—while not identical to actual quantum physics—shows, by example, *how it could be* that local, deterministic laws produce a quantum-like interference-observation duality. Everett’s formulation does the same, for a more complicated example: the real world.

Everett’s interpretation of quantum mechanics accounts for actual quantum phenomena in terms of an elegant formalism—one so basic to the phenomena that even the Copenhagen interpretation invokes that formalism, together with a gratuitous complication, the quantum collapse. Everett’s model *explains* quantum observation—its nature can be deduced from the model—instead of requiring an ad hoc, imprecisely specified distinction between observation interactions and all other physical interactions.

The quantish physics model is much simpler than, but deeply similar to, Everett’s formulation. Quantish physics faithfully exhibits not only the fundamental quantum interference-observation duality, but also (with respect to particles’ attributes) Heisenberg’s impossibility of eliminating interfering superposition without thereby introducing some complementary superposition. By abstracting away from the complexity of real-world wave mechanics, quantish physics allows one to devote full attention to what is special and perplexing about quantum uncertainty.

Quantish physics may be helpful for introducing quantum mechanics to undergraduates (perhaps even to many high school students; no mathematics beyond high-school level is involved), and for explaining quantum uncertainty to the technically oriented segment of the general population. I think doing so would be important, for more than the usual reasons of scientific literacy. It is important that we understand what kind of world we inhabit—a world explained by mechanical principles, not driven by the whims of spirits—because it is important to understand how to find the truth: by rational inquiry, not by appeal to superstition and to superstitious social institutions. The conventional, Copenhagen interpretation of quantum mechanics is incoherent, and so makes reality itself seem incoherent. Nothing could be further from the truth.

## Acknowledgments

I am grateful to Alan Bawden for spotting or solving several conceptual and expository problems in earlier versions of this work. And I appreciate the helpful suggestions made by Phil Agre, David Chapman, Eric Cohen, Jim Davis, Ian Horswill, Jerry Roylance, and Dan Weld. This paper revises an earlier one written for my CS area exam. I thank my area exam committee—Marvin Minsky, Ronald Rivest, Gerald Sussman, and (virtually) Tom Knight—for supporting this topic and for their helpful comments and advice.

## References

- [Aspect82] Aspect, A., J. Dalibard, and G. Roger, “Experimental Test of Bell’s Inequalities Using Time-Varying Analyzers”, *Physical Review Letters*, vol. 49, p. 1804, 1982.
- [Bell64] Bell, J. “On the Einstein-Podolsky-Rosen Paradox”, *Physics* vol. 1, p. 195, 1964.
- [Cohen-Tannoudji] Cohen-Tannoudji, C, B. Diu, and F. Laloë, *Quantum Mechanics*, New York: Wiley, 1977.
- [deBroglie64] deBroglie, L. *The Current Interpretation of Wave Mechanics*, Amsterdam: Elsevier, 1964.
- [Deutsch86] Deutsch, D. “Three Connections Between Everett’s Interpretation and Experiment”, in Penrose and Isham, eds. *Quantum Concepts in Space and Time*, Clarendon Press, 1986.
- [Einstein35] Einstein, A., B. Podolsky and N. Rosen, “Can Quantum-Mechanical Description of Physical Reality be Considered Complete?”, *Physical Review*, vol. 47, p. 777, 1935.
- [Everett57] Everett, H. “‘Relative State’ Formulation of Quantum Mechanics”, *Reviews of Modern Physics*, vol. 29, p. 454, 1957.
- [Fredkin82] Fredkin, E. and T. Toffoli, “Conservative Logic”, *International Journal of Theoretical Physics*, vol. 21, p. 219, 1982.
- [Nozick81] Nozick, R. *Philosophical Explanations*. Cambridge: Harvard, 1981.
- [von Neumann55] von Neumann, J. (R.T. Beyer, English translation), *Mathematical Foundations of Quantum Mechanics*, Princeton: Princeton, 1955.

*This blank page was inserted to preserve pagination.*



# Scanning Agent Identification Target

Scanning of this document was supported in part by the **Corporation for National Research Initiatives**, using funds from the **Advanced Research Projects Agency** of the **United States Government** under Grant: **MDA972-92-J1029**.

The scanning agent for this project was the **Document Services** department of the **M.I.T. Libraries**. Technical support for this project was also provided by the **M.I.T. Laboratory for Computer Sciences**.

